

# TAOS SERIES

## Outdoor Condensing Units

### Installation & Operating Instructions



**CROWN**  
Boiler Co.

**Attention Installer:**

**System Check List shall be  
completed as per instructions.**



---

## **INSPECTION**

This product has been inspected at the factory and released to the transportation agency without known damage. Inspect exterior of carton for evidence of rough handling in shipment. Unpack carefully, if damage is found, report immediately to the delivering motor freight carrier.

## **IMPORTANT**

The United States Environmental Protection Agency (EPA) has issued various regulations regarding the introduction and disposal of refrigerants in this unit. Failure to follow these regulations may harm the environment and can lead to the imposition of substantial fines. Because these regulations may vary due to the passage of new laws, a certified technician must do any work on this unit. Should you have any questions please contact the local office of the EPA.

This product is designed to be installed and serviced by professional, trained HVAC contractors. Always use licensed professionals for installation of this product.

## **IMPORTANT MESSAGE TO OWNER**

These instructions should be carefully read and kept near the product for future reference. While these instructions are addressed primarily to the installer, useful maintenance information is included. Have your installing dealer acquaint you with the operating characteristics of the product and periodic maintenance requirements; to include system cleaning and performance evaluation by a professional, trained HVAC contractor. The minimum level of annual maintenance for a cooling system should include:

1. Check operating pressures
2. Check compressor voltage and amperage
3. Check condenser fan motor voltage and amperage
4. Check for adequate refrigerant charge
5. Measure evaporator superheat
6. Measure temperature difference across evaporator
7. Lubricate all moving parts
8. Check evaporator cleanliness
9. Check filter condition
10. Check compressor contactor points
11. Check and adjust thermostat
12. Hydraulically clean condenser coil
13. Clear evaporator condensate drain and lines
14. Analyze capacitors
15. Check compressor crankcase heater(If applicable)

## **CODES AND REGULATIONS**

This product is designed and manufactured to permit installation in accordance with National Codes and/or prevailing local codes and regulations.

## **REFERENCE**

Use this instruction in conjunction with the instructions for the appropriate indoor unit air moving system and accessories.

Installer should pay particular attention to the words NOTE, CAUTION and WARNING.

NOTES are intended to clarify or make the installation easier.

CAUTIONS identify procedures, which, if not followed carefully, could result in personal injury, property damage or product damage.

WARNINGS are given to alert the installer that severe personal injury, death or equipment damage may result if installation procedures are not followed properly.

---

## **SAFETY NOTICE**

This information is intended for use by individuals possessing adequate backgrounds of electrical and mechanical experience. Any attempt to repair a central air conditioning product may result in personal injury and/or property damage. The manufacturer or seller cannot be responsible for the interpretation of this information, nor can it assume any liability in connection with its use.

## **SAFETY WARNING**

All parts of this product capable of conducting electrical current are grounded. If grounding wires, screws, straps, clips, nuts or washers used to complete a path to ground are removed for service, they must be returned to their original position and properly fastened.

Installation and service should be performed only by a qualified licensed professional.

## **LIMITATIONS**

Caution: The manufacturer is not responsible for the performance of a mismatched system. The outdoor unit must be installed with a compatible indoor unit as designated in the specification data or in the ARI directory. Using unmatched components may affect the performance of the system and will void the warranty of the equipment.

Do not install a precharged coil to a furnace that is to be operated during the heating season without first attaching the refrigerant lines to the coil and charging the system. Allowing the coil charge to enter the refrigerant lines prevents excessive refrigerant pressure build-up and possible coil damage.

## **REPLACEMENT PARTS**

Order all replacement parts through your local distributor. When ordering parts, give complete model and serial number as shown on the unit nameplate.

## **INSTALLATION LOCATION**

The condensing unit is designed to be located outside the building with free unobstructed condenser air inlet and discharge. Additionally the unit must be situated to permit access for service after the installation. Condenser air enters from all sides. A minimum of 12" clearance to walls or air obstructions is required. Refrigerant tube and electrical connections are made on the side so indicated by control panel cover and refrigerant valve locations. Control panel access requires a minimum 36 inches.

The best installation practice will minimize exposed tubing and allow access for service.

Air discharges upward from the top of the unit. The top shall be completely unobstructed. If the unit is to be located under an overhang, there should be a minimum of 60" clearance and provision made to deflect the warm discharge air out from the overhang.

The condensing unit must be mounted on a solid, level foundation, i.e. preformed concrete slab or other suitable base. For rooftop application, ensure that the building construction can support the weight and that proper consideration is given the weather-tight integrity of the roof. The condensing unit contains moving components and can vibrate; therefore, dynamics and sound are a consideration in all applications. Since these units discharge warm condenser air from the top with cooler air being drawn in from the sides, nonbearing/no-shedding plantings can be made in relatively close proximity to the unit. Owners should be advised to insure that lawn mower, or other discharges, do not deposit debris on the fin coil surface reducing product efficiency.

See Fig. 1 for relative elevation limitations and Table 1 for refrigerant line lengths and associated outside line diameters.

---

## **ELECTRICAL SERVICE**

### **WARNING**

To prevent electrical shock, turn off the remote disconnect so that there is no electrical supply to outdoor unit. The internal contactor does not open both sides of the 208/230-volt electrical circuit in all units.

Electrical installation will consist of power supply wiring to the condensing unit as well as control wiring between thermostat, indoor unit and the condensing unit. All wiring must be in accordance with the National Electrical Code and all local codes that may apply. (See unit-wiring diagram furnished with the unit and/or this instruction).

The condensing unit nameplate and the table inside the front cover of this instruction manual lists pertinent electrical data necessary for the selection of proper size electrical service and over-current protection. The owner should be made familiar with the location of the over-current protection, the proper size for this application, and the proper procedure for disconnecting power to the unit.

The condensing unit control wiring requires a 24, volt minimum 25 VA, service from the indoor transformer as shown on the wiring diagram. Minimum wire size recommended for control wiring is 18 AWG (wire gauge may need to be increased depending upon length of wire run).

### **REFRIGERANT TUBING**

Use only refrigerant grade (dehydrated and sealed) copper tubing of the size indicated in Table 1 to interconnect the condensing unit with the indoor evaporator. Take extreme care to keep the refrigerant tubing clean and dry prior to, and during, installation.

Do not remove plugs from ends of tubing until connection is ready to be made.

Suction line insulation is necessary to prevent condensation from forming on and dropping from the suction line. In severe applications (hot, high humidity areas), greater insulation values may be required (consult and comply with code requirements). Apply suction line insulation by sliding it on the sealed tubing before cutting and making connections. (See Fig. 2)

### **ORIFICE SELECTION (ORIFICE TYPE COILS ONLY)**

**NOTE:** The proper orifice must be installed in the evaporator coil liquid line connection prior to the connection of the refrigerant lines!

**WARNING:** Some coils may be under pressure as supplied from manufacturer.

Each coil has an orifice installed in the fitting between the liquid line connection and distributor. The orifice is identified.

The orifice shipped with the indoor coil is based on a specific combination of products. The indoor coil orifice may be changed, depending on the capacity and efficiency of the outdoor unit, elevation differences, and/or total line lengths.

See the appropriate Data Sheet for the correct orifice size.

### **SYSTEM BRAZING**

**CAUTION: USE EXTREME CARE IN REMOVING THE CAPS FROM THE SUCTION AND LIQUID LINE FITTINGS, AS THERE MAY BE PRESSURE PRESENT.**

**The following are instructions on the field connection to the valve, and valve opening procedures.**

1. Tubing should be cut square. Make sure it is round and free of burrs at the connecting ends. Clean the tubing to prevent contamination from entering the system.
2. Remove valve top caps and valve cores. Keep the caps and cores in a clean area so contamination does

---

not get in or on the parts. This is important in order to ensure that when the parts are replaced, the valves will properly seat and no contamination has entered the system.

3. Use a heat sink or wet rag around the copper valve stub to insure no damage is caused during brazing. Do not allow valve body temperature to reach 250°F or above.
4. Braze or silver solder the required joints pointing torch away from the valves.
5. After brazing and valve core replacements, evacuate and charge the connecting lines as outlined in the Installation and Operating instructions. Replace caps when complete.
6. Using the proper Allen wrench open the valve bodies approximately 5 complete turns until lightly back seated against retaining ring. NOTE: Excessive force will damage retaining ring and must be avoided. Replace retaining ring if damaged before proceeding.
7. Replace the valve caps finger tight and tighten with a wrench an additional 1/6th turn to ensure sealing.

## **SYSTEM START UP**

Condensing units are supplied with R-22 charge sufficient for typical matching evaporator and approximately 25' of interconnecting tubing (25' suction line & 25' liquid line). Condensing unit liquid and suction valves are closed to contain the charge within the unit. The recommended procedure for processing and charge adjustment is as follows:

1. Connect service gauge manifold to both base valve service ports, and vacuum pump to gauge manifold.
2. Evacuate tubing and evaporator thru liquid and suction base valve ports, to 500 microns or less for a minimum of 30 minutes (evacuation time must be adequate to remove moisture). Close valve to pump and wait 15 minutes. Vacuum should not rise above 800 microns. If unable to obtain 500 microns, or vacuum rises above 800 microns over the 15-minute period, discontinue evacuation, pressurize with dry nitrogen and check for leaks. Repair any leaks found and repeat step 2.
3. Close valve to vacuum pump and stop pump. Break the vacuum by opening liquid and suction valves. Fully open base valves and remove pump lines. Connect service gages being sure to purge lines.
4. Set thermostat system switch to "cool" and temperature to highest setting. Close all disconnects and wait 30 minutes if compressor has crankcase heater.
5. Set thermostat to call for cooling. Check for operation of indoor and outdoor fans.
6. After system stabilizes (minimum 10 minutes). Check charge and adjust if necessary. (Refer to Appropriate "Checking Charge" section).

## **CHECKING CHARGE – CAPILLARY TUBE / FIXED ORIFICE SYSTEM**

1. Fully open both base valves.
2. Connect service gage manifold to base-valve service ports remembering to purge the lines. Run the system at least 10 minutes to allow pressures to stabilize.
3. Temporarily install an accurate thermometer on the suction line (large line) near the condensing unit. Ensure that good contact is made between the thermometer and the line. Wrap the thermometer with insulating material to assure an accurate reading of the suction line refrigerant temperature.
4. Refer to Table 2 for proper system superheat. Add charge to lower superheat. Remove & recover charge to raise superheat.
5. Remove the gage line carefully. CAUTION: Escaping liquid refrigerant can cause burns.

## **SUPERHEAT CAN BE DETERMINED AS FOLLOWS**

- Read the suction pressure, and using Table 3, convert it to the saturated suction temperature.
- Read suction line temperature.

---

SUPERHEAT = SUCTION LINE TEMPERATURE – SATURATED SUCTION TEMPERATURE

### **CHECKING CHARGE - EXPANSION VALVE SYSTEM**

1. Fully open both base valves.
2. Connect service gage manifold to base-valve service ports remembering to purge the lines. Run the system at least 10 minutes to allow pressures to stabilize.
3. Temporarily install accurate thermometer to the liquid (small) line near the condensing unit. Ensure that good contact is made between the thermometer and the line. Wrap thermometer with insulating material to ensure accurate reading of the refrigerant temperature.
4. Adjust charge to obtain a temperature of 12 to 15 degrees F below the condensing temperature determined from Table 4.

**Example:** Liquid Pressure = 260 PSIG.

Therefore, the Condensing Temperature = 120 degrees F.

120 degrees – 15 degrees = 105 degrees.

Adjust Charge to obtain a Liquid Line Temperature of 105 degrees F.

**IMPORTANT:** COMPLETE INSTALLER'S GUIDE "CHECKOUT PROCEDURE" and REVIEW WITH END USER (for new construction, complete and provide to appropriate authority for future end user).



### 1. Piping Length and Elevation

COND UNIT (TONS)	LENGTH "A" IN FT MAX	LENGTH "B" IN FT MAX
1.5	82	50
2	82	50
2.5	82	50
3	82	50
3.5	82	50
4	82	50
5	82	50

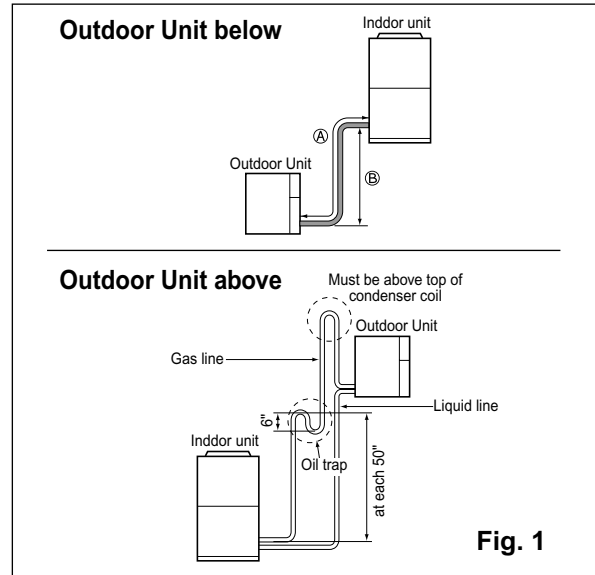

### 2. Vapor Line Insulating

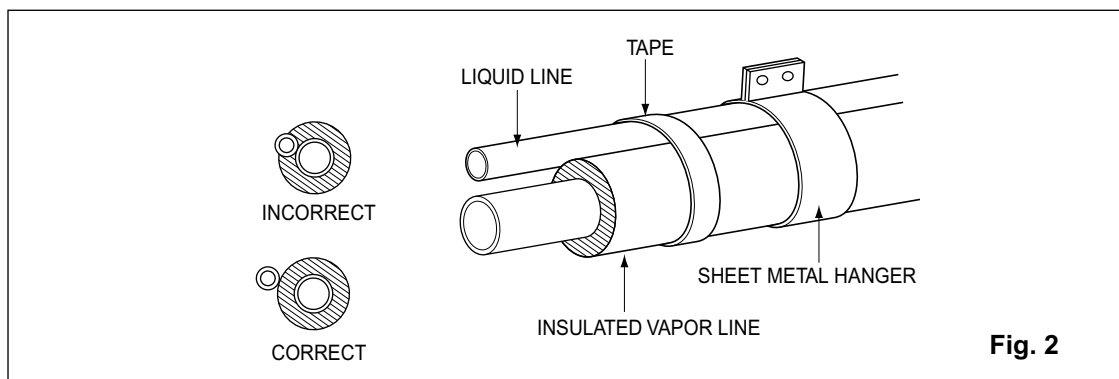

### 3. Condensing Unit

COND UNIT (TONS)	unit:inch		
	A	B	C
1.5	27 11/16	24 21/32	22 11/16
2			
2.5			
3 & 3.5	32 5/8	28	27
4			
5			

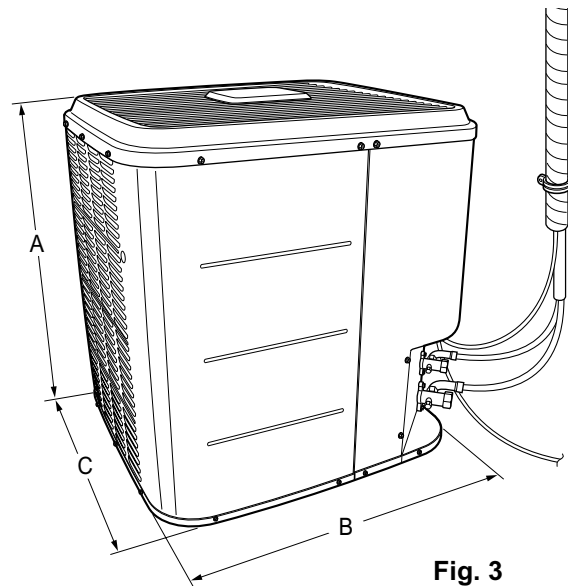

## 4. Wiring Diagram

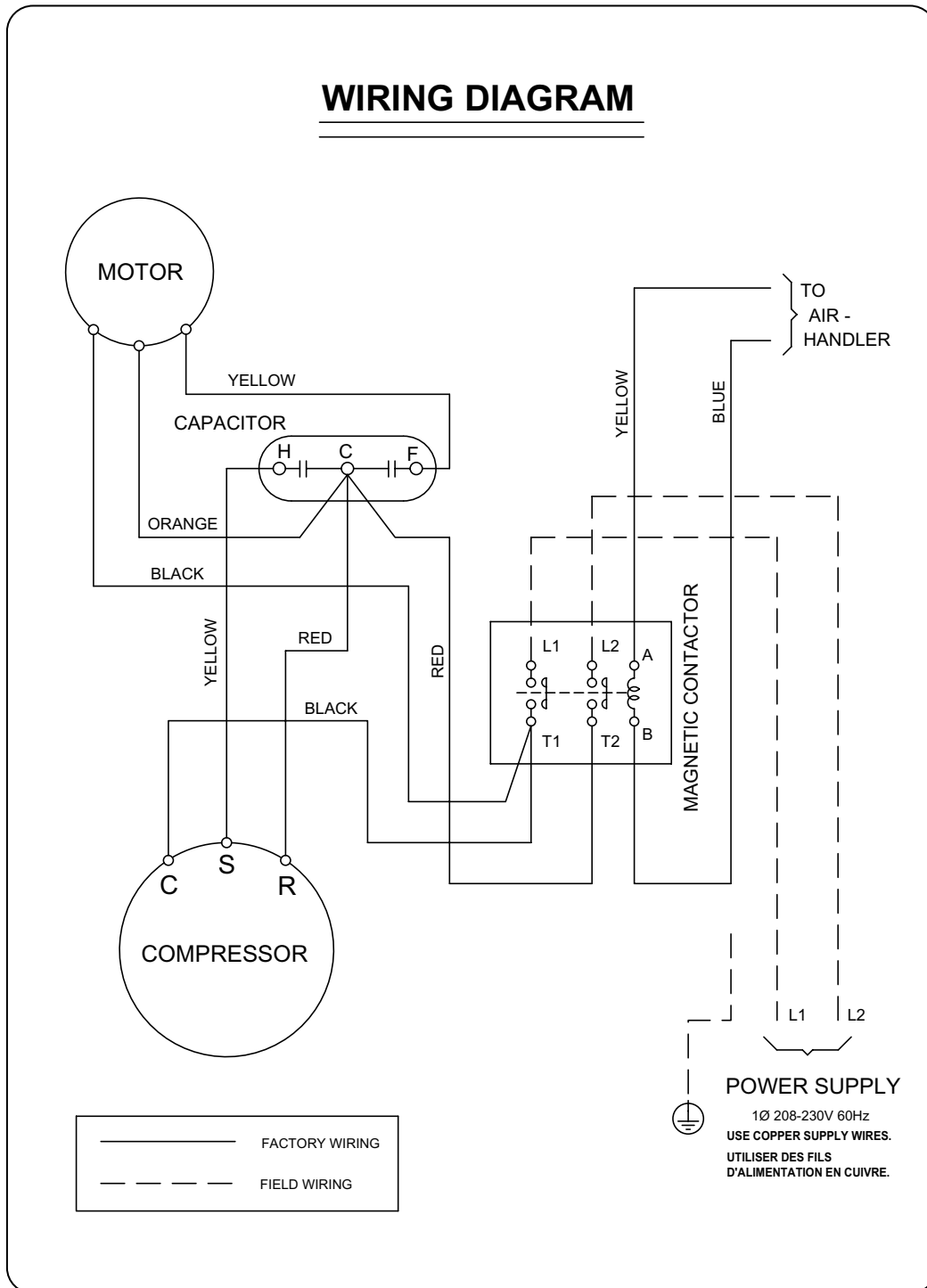

---

# SYSTEM INSTALLER'S GUIDE - CHECK LIST

**CHECKOUT PROCEDURE** (After completion, review and leave with home owner or as directed)

Date of Installation \_\_\_\_\_

Model Number \_\_\_\_\_ Serial Number \_\_\_\_\_

Installing Contractor Name \_\_\_\_\_

Installing Contractor Phone Number \_\_\_\_\_

After installation has been completed, it is required that the entire system be checked against the following list:

1. Refrigerant Line, Leak checked ( )
2. Suction Lines and Fittings properly insulated ( )
3. Have all Refrigerant Lines been secured and isolated properly? ( )
4. Have passages through masonry been sealed? If mortar is used, prevent mortar from coming in direct contact with copper tubing ( )
5. Indoor coil drains freely. Pour water into drain pan ( )
6. Supply registers and return grilles are open and unobstructed ( )
7. Return air filter installed ( )
8. Thermostat thermometer is accurate, and thermostat is level. ( )
9. Is correct speed tap being used? (Indoor blower motor) ( )

---

## SYSTEM OPERATIONAL CHECK

**IMPORTANT:** To prevent compressor damage which may result from the presence of LIQUID refrigerant in the crankcase, these procedures should be followed at initial Start-Up and at anytime the power has been off for 12 hours or more if the compressor uses a crankcase heater.

1. Place the thermostat's system switch in the "OFF" position and apply power by closing system disconnect switch. Allow the system to remain off, but with power supplied for a minimum of one hour if compressor uses a crankcase heater.

**OPERATING PRESSURES:** After the unit has operated in the cooling mode for 15 minutes, install pressure gauges on the gage ports of the liquid and suction valves. Check the suction and liquid line pressures and compare them to the normal operating pressures provided in the unit's Service Manual.

### **NOTE: TO CHARGE THE SYSTEM ACCURATELY, USE SUPERHEAT OR SUBCOOLING METHOD DEPENDING ON THE FLOW CONTROL USED IN THE SYSTEM.**

2. Except as required for safety while servicing: DO NOT OPEN SYSTEM DISCONNECT SWITCH.
3. Measure and record the following:

■ Line voltage @ contactor during start-up	:	_____	VAC
■ Compressor amperage	:	_____	Amps
■ Condenser Fan Amperage	:	_____	Amps
■ Suction Pressure	:	_____	PSIG
■ Liquid Line Pressure	:	_____	PSIG
■ Superheat	:	_____	*F
■ Sub-cooling	:	_____	*F
■ Outdoor temperature	:	_____	*F
■ Indoor temperature	:	_____	*F

## SUPPLEMENTARY HEATERS CHECKOUT PROCEDURES, IF USED

DOES HEATER REQUIRE A SEPARATE CIRCUIT \_\_\_\_\_ ?

4. Ensure that the disconnect switch is "OFF", and the safety label (if any) is attached ( )
5. Check field wiring for sound connections and grounding according to codes ( )
6. Check fuses or breakers for proper size per nameplate specifications ( )
7. Check control box panel – in place and secured ( )

### **NOTE: OPERATION OF HEATERS MUST BE CHECKED DURING THE OPERATION CHECK OF THE TOTAL SYSTEM**

# EXPLODED VIEW

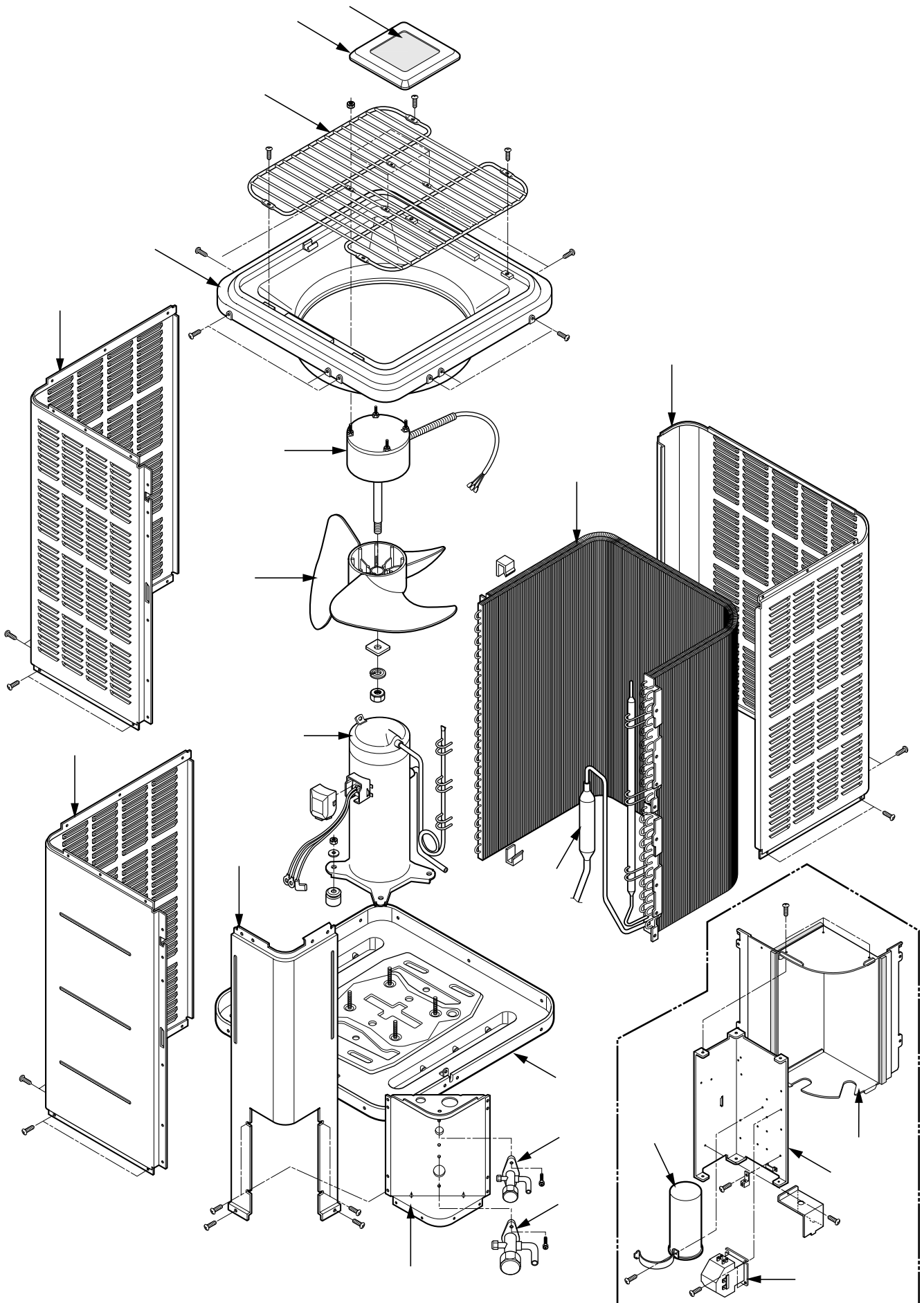

**PARTS LIST: 2AC10018 / 2AC10024 / 2AC10030 / 2AC10036 / 2AC10042**

LOCATION	PART NAME	TF PN:	2AC10018	2AC10024	2AC10030	2AC10036	2AC10042
1	UPPER PANEL	610263	1	1	1	1	1
2	PANEL SIDE	610279	1	1	1	1	1
3	PANEL SIDE	610281	1	1	1	1	1
4	PANEL SIDE	610282	1			1	
5		610297		1	1		1
6	BASE ASSY.	610277	1			1	
		610296		1	1		1
7	GRILLE DISCHARGE	610278	1	1	1	1	1
8	MOTOR ASSY.	610264		1	1	1	1
		610284	1				
9	SERVICE VALVE (3/8")	610289	1	1	1	1	1
10	SERVICE VALVE (3/4")	610290	1	1	1	1	
	SERVICE VALVE (7/8")	610301					1
11	CONDENSER COIL	610272				1	
		610291	1				
		610269		1	1		
		610302					1
12	COMPRESSOR SET	610252				1	
		610249			1		
		610295		1			
		610275	1				
		610303					1
13	DRIER ASSY.	610242	1	1	1	1	
		610304					1
14	FAN BLADE ASSY.	610270	1	1	1	1	1
15	CONTROL BOX	610287	1	1	1	1	1
16	CONTACTOR, SWITCH	610261	1	1	1	1	1
17	LOGO LABEL	610283	1	1	1	1	1
18	CAPACITOR	610262			1	1	
		610300		1			
		610294	1				
		610096					1
19	BRACKET	610285	1	1	1	1	1
20	BRACKET	610286	1	1	1	1	1
21	LOGO PLASTIC CAP	610288	1	1	1	1	1

# Memo



A series of horizontal dotted lines spaced evenly down the page, providing a template for writing a memo.

# CROWN Boiler Co.

Manufacturer of Hydronic Heating Products  
P.O. Box 14818 3633 I. Street  
Philadelphia, PA 19134

Tel: (215) 535-8900 • Fax: (215) 535-9736 • [www.crownboiler.com](http://www.crownboiler.com)