



FW SERIES

**CAST IRON
3-PASS SCOTCH-
MARINE BOILER**
Designed for use with
light oil, gas, or a light
oil-gas combination

I=B=R BURNER INPUT
433,000 to 1,299,000
BTU/HR

FW Series Features

- ✓ **3 PASS SCOTCH-MARINE DESIGN, MAXIMIZING HEAT TRANSFER**
- ✓ **CAST IRON PUSH NIPPLES AND BOILER SECTIONS**
- ✓ **WOVEN GLASS ROPES BETWEEN SECTIONS**
- ✓ **SWING-OPEN BURNER DOOR FOR EASY SERVICE AND INSPECTION**
- ✓ **PRESSURIZED FOR FORCED DRAFT VENTING OR CHIMNEY DRAFT**
- ✓ **STAINLESS STEEL BAFFLES EASILY REMOVED VIA FRONT DOOR**
- ✓ **REAR FLUE OUTLET WITH QUADRANT LOCKING DAMPER**
- ✓ **EXCLUSIVELY DESIGNED FOR FORCED HOT AIR CIRCULATION**
- ✓ **POWDER COATED, TEXTURED, INSULATED JACKET**
- ✓ **10-YEAR LIMITED WARRANTY**

CrownBoiler.com



FW SERIES

TECHNICAL INFORMATION

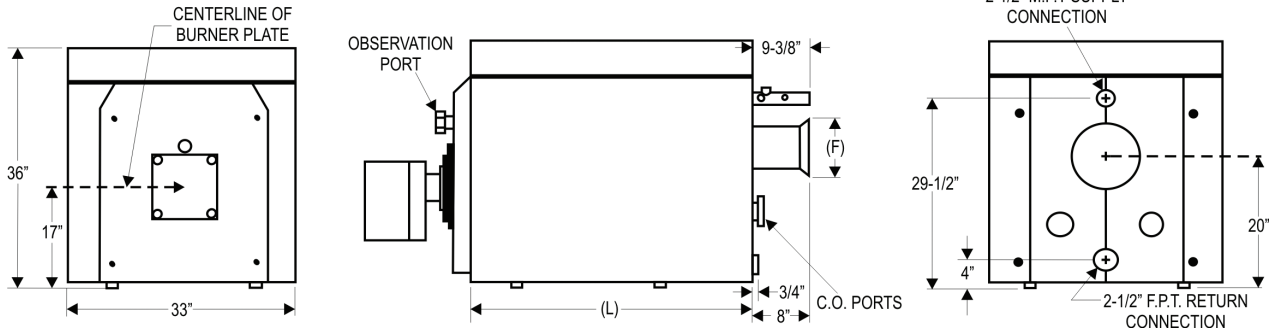

The Crown FW series is designed for applications requiring a high efficiency, compact, hydronic boiler. Cast iron sections are fully assembled. The rugged swing door exposes all heating surfaces for direct visual inspection and facilitates maintenance. Circular water backed design requires no refractory combustion chamber. The supply manifold speeds installation and simplifies placement of controls.

RATINGS AND SPECIFICATIONS

BOILER MODEL	I=B=R BURNER INPUT		I=B=R GROSS OUTPUT*		I=B=R NET RATING** WATER MBH	APPROX DRY WEIGHT (LBS.)	VENT CONNECT DIAMETER (INCHES) [F]	I=B=R VENT DIA. (INCHES)***	[L] (INCHES)	WATER CONTENT (GAL.)	DRAFT LOSS (IN. W.C.)
	OIL GPH	GAS MBH	MBH	BHP							
FW-4	3.0	433	355	10.6	309	948	8	7	26	15.8	0.16
FW-5	4.0	577	478	14.2	416	1124	8	7	37	19	0.27
FW-6	5.0	722	600	17.9	522	1301	10	8	42	22.2	0.39
FW-7	6.0	866	723	21.6	629	17477	10	9	47	25.4	0.51
FW-8	7.5	1082	907	27.1	789	1654	10	10	52	28.5	0.62
FW-9	9.0	1299	1091	32.6	949	1831	10	10	57	31.7	0.75

* Gross I=B=R ratings have been determined under the I=B=R provisions governing forced draft conditions. (0.10 inch W.C. positive pressure at the boiler flue gas outlet.)

** Net ratings are based on piping and pick up allowance of 1.15.

*** I=B=R Vent Diameter size is the pipe size used from boiler vent connector (F) to termination of stub stack; Max. Height 15' (for forced draft firing only). For chimney venting consult National Fuel Gas Code.

BURNER DATA OPTIONS

BOILER MODEL	BURNER MOTOR			BURNER MODEL LIGHT OIL	BURNER MODEL GAS	BURNER MODEL GAS/OIL COMB.	GAS TRAIN SIZE	MIN. GAS PRESSURE REQ. @ BURNER (IN. W.C.)
	MFG.	HP	VOLTAGE					
FW-4	BECKETT	1/3	120-1	CF-500	----	----	----	----
	POWER FLAME	1/3	120-1	C1-0	C1-G-10	C1-GO-10	1-1/4	5.5
FW-5	BECKETT	1/3	120-1	CF-800	----	----	----	----
	POWER FLAME	1/3	120-1	C1-0	C1-G-10	C1-GO-10	1-1/4	5.5
FW-6	BECKETT	1/3	120-1	CF-800	----	----	----	----
	POWER FLAME	1/3	120-1	C1-0	C1-G-10	C1-GO-10	1-1/4	5.5
FW-7	BECKETT	1/2	120-1	CF-1400	----	----	----	----
	POWER FLAME	1/3	120-1	C1-0	C-G-10	C1-GO-10	1-1/4	5.5
FW-8	BECKETT	1/2	120-1	CF1400	----	----	----	----
	POWER FLAME	3/4	230-1	C2-OA	C2-G-15	C2-GO-15	1-1/2	7.0
FW-9	BECKETT	1/2	120-1	CF-2300	----	----	----	----
	POWER FLAME	3/4	230-1	C2-OA	C2-G-15	C2-GO-15	1-1/2	7.0

- 1) All burners are LO-HI-OFF except Beckett CF-500 and CF-800 which are ON-OFF operation.
- 2) Standard burner certification is U.L. special high risk insurance package. Available IRI, FIA, FM.
- 3) Burners are shipped in a separate crate (when ordered).
- 4) Burner Blast Tube Insertion 4-3/4".

CROWN'S THREE-PASS DESIGN

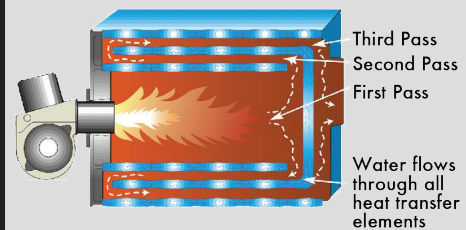

This unique and dependable 3-pass wet base principle is built on the "Scotch Marine" design. Fuel economy is optimized by the completely cylindrical combustion chamber (1st pass). Flue gases are directed into four of the concentric annular passageways (2nd pass). The gasses return to the front of the boiler, and enter the remaining passageways (3rd pass), which lead to the rear flue outlet.



CrownBoiler.com

PHILADELPHIA, PA